



Donaldson
FILTRATION SOLUTIONS
AEROSPACE & DEFENSE

**DONALDSON ROTORCRAFT INLET
BARRIER FILTER SYSTEM FOR
ROBINSON R66 TURBINE HELICOPTERS**



INSTALL BEFORE FLIGHT

Helicopters routinely contend with dust, sand and debris that attack turbine engines and impact engine reliability. Installing an Inlet Barrier Filter (IBF) system is the most effective way to protect engines from damage – ranging from lost efficiency to catastrophic failure – while adding significant advantages.

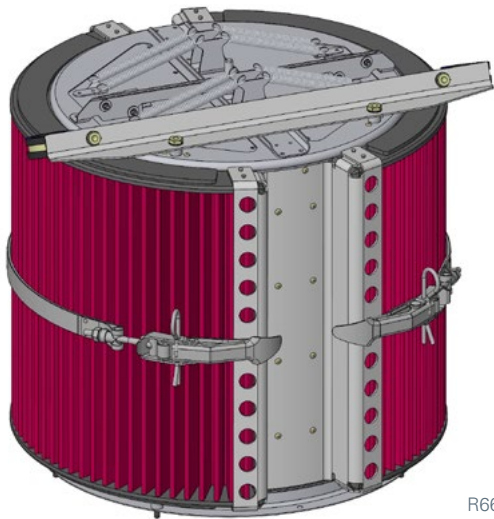

R66 IBF

KEY BENEFITS

- More power available than alternate filtration solutions
- Reduces engine turbine operating temperatures
- Reduces engine maintenance costs
- Longer engine life due to elimination of corrosion
- Improves time between engine overhaul requirements
- Better performance in extreme environments

PERFORMANCE AT-A-GLANCE

R66 IBF KIT | PART NUMBER 146000-101

Design Features	Delivered flat, this flexible filter curves upon installation for 320 degrees of coverage and exceptional drive shaft protection. The filter, which can be quickly installed in less than a day with two easy steps, replaces the existing R66 filter with Donaldson high-performance oiled media for superior IBF protection.
Filter Life (Service Cycles)	4,500 hours (15 cycles every 300 hours)
Emergency Bypass	The Donaldson IBF utilizes the existing bypass system.
Components	The IBF system incorporates a filter maintenance aid for on-condition monitoring while an aircraft is on the ground, enabling pre- and post-flight filter health assessment.
Performance	The filter is approved* for installation worldwide.
Certificates	FAA certification is pending award to Robinson Helicopter Company. Call for latest updates.

*Pending FAA Approval

For more information, contact:

Donaldson Company, Inc., Aerospace & Defense Group
17891 Chesterfield Airport Road, Chesterfield, MO 63005

North America +1-877-314-9640
aerospace.americas@donaldson.com

Europe +33 1 30866698
aerospace.emea@donaldson.com

To learn more about the
Donaldson Company, Inc., Aerospace & Defense Group
visit www.DonaldsonRotorcraft.com

Brochure No. F112280 (02/17)

© 2017 Donaldson Company, Inc. All rights reserved.
Donaldson Company, Inc. reserves the right to change or discontinue any
model or specification at any time and without notice. Printed in the U.S.A.